

PRELIMINARY PARTICULARS - PRELET OPPORTUNITY

46 High Street, Harrow, Wealdstone, HA3 7AE

GN|2



**E (formerly A1)
PRE-LET OPPORTUNITY**

46 High Street, Harrow, Wealdstone, HA3 7AE

851 SQ Ft / 79 sqm

GN|2

www.gn2.uk.com

PRELIMINARY PARTICULARS - PRELET OPPORTUNITY

46 High Street, Harrow, Wealdstone, HA3 7AE



PROPERTY DETAIL:

Harrow High Street provides central shopping amenities to the local surrounding area, with excellent access to the London Underground and main line train services via Harrow and Wealdstone Station.

The Premises occupy a prominent pitch the fronting the High Street. Located over ground the floor the premises provides mainly open plan sales area with excellent frontage and would suit a variety of concepts.

The property will benefit from the wider re-development of "Premier House" on the upper floors which will include 112 No. residential flats and additional commercial space, completion due in Q1 2024.

Indicative layout plan:

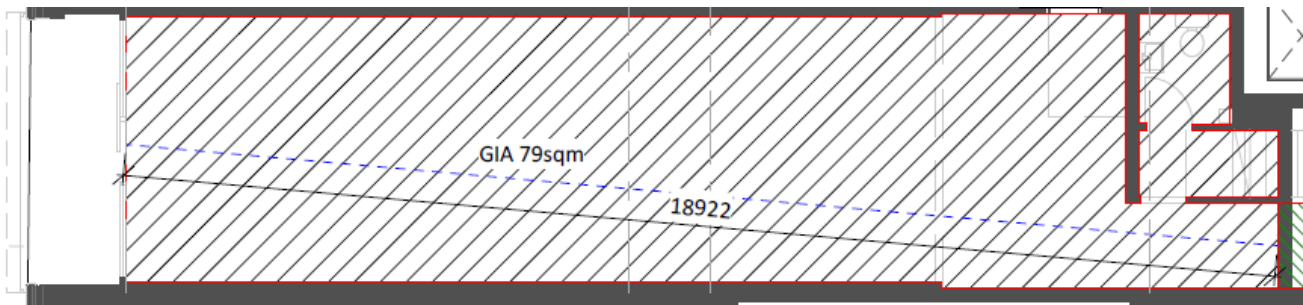

Floor Areas:

Floor	SQ FT	SQ M
Ground Floor	851 sqft	79 sqm
Total	851 sqft	79 sqm

*Alternative commercial space available on enquiry.

Term: Pre-let opportunity for a new lease available outside the Landlord and Tenant Act 1954 part II

RENT: £25,000 per annum

Rateable Value: RV£17,750

Service charge: TBC

EPC: B

Contact GN2:

Tim Powell-Harper

DDI: 0207 183 5916

Mobile: 07798 527 677

EMAIL: tim.powellharper@gn2.uk.com

Nick Moore

DDI: 0207 183 6554

Mobile: 07825702700

EMAIL: nick.moore@gn2.uk.com